

Modellname: **ATLANTA**
 Nazwa modelu:

Modellreihe: **02**
 Numer modelu:

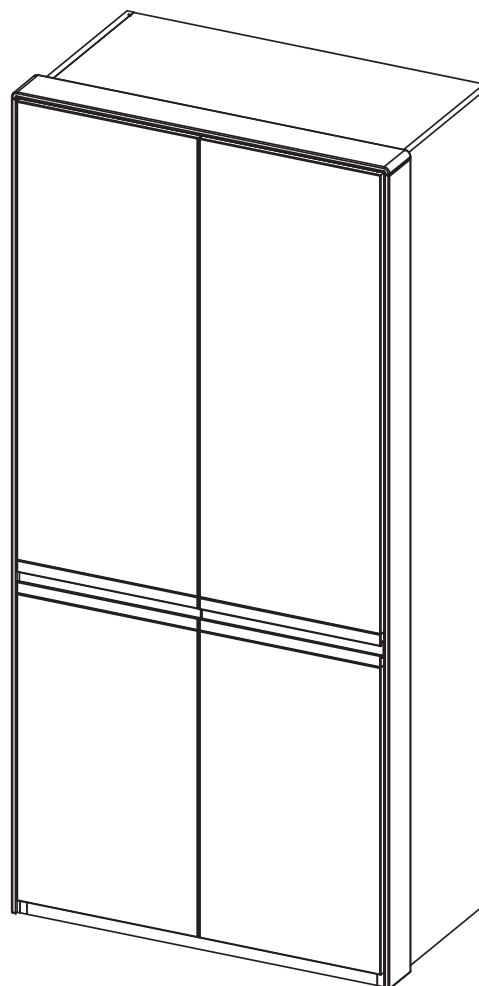

MONTAGEANLEITUNG * INSTRUKCJA MONTAŻOWA

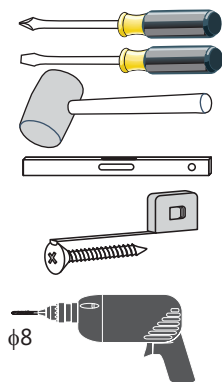

Pflegehinweis!

Bitte nur mit einem Staubtuch oder einem feuchten Lappen reinigen.

KEINE scheuernde Putzmittel verwenden!

Wskazówka dotycząca pielęgnacji!







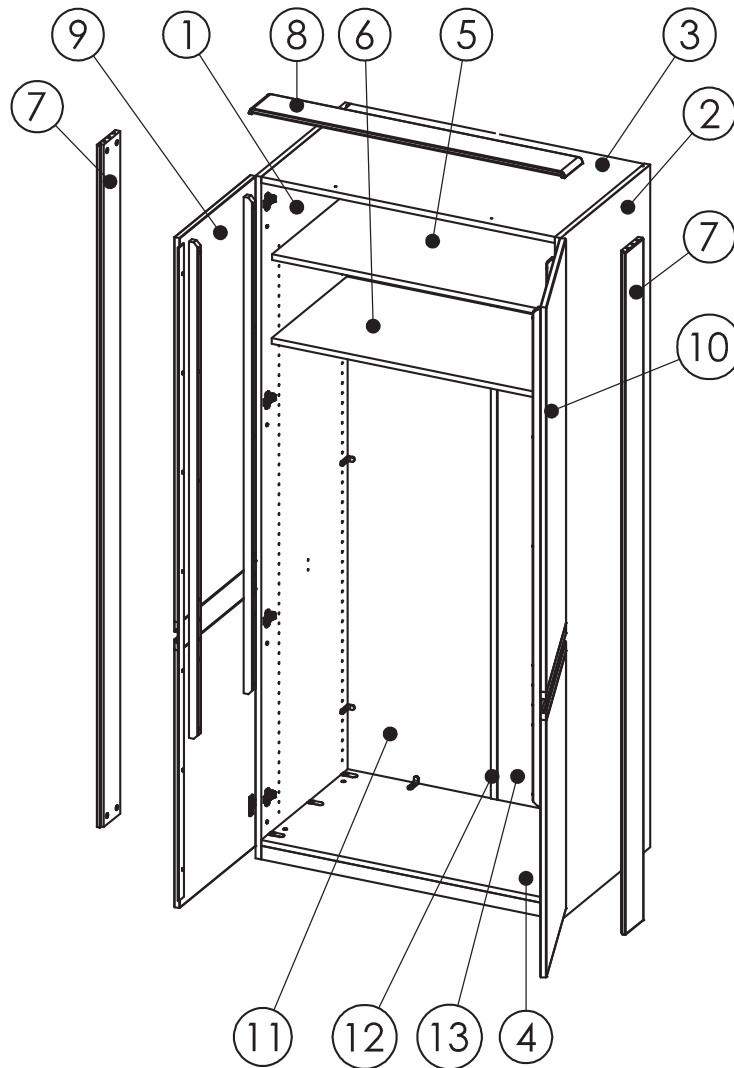







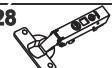

Proszę czyścić tylko suchą lub lekko wilgotną szmatką do kurzu. Nie używać żadnych środków szorstkich!

max. zulässige Belastungen von Einlegeböden in Kg: max. dopuszczalne obciążenie półki w Kg:									
Länge dlug.	Stärke obciążenie mm	Massivholz/Masyw			Spanplatte/Płyta			Glas/Szkoło	RW mit Boden
		15	18	20	15	18	22	5 / 6 / 8	
0 ≤ 400									Länge 1000 mm max 5kg%
401 ≤ 600	20	20	20	15	15	15	Länge bis/ dlug. do 600 mm / 10kg		
601 ≤ 800				10			Länge bis/ dlug. do 900 mm / 5kg		
801 ≤ 1000	10			5	5				

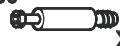
1

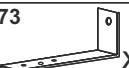

Zestawienie okuć / Allgemeiner Beschlagsatz

Worek1 Beutel1	Worek2 Beutel2	Worek3 Beutel3	Worek4 Beutel4	Worek5 Beutel5
<p>004838  x2</p> <p>000070  3,5x13 x2</p> <p>002629  x10</p> <p>000021  3,5x16 x10</p>	<p>004992  x16</p> <p>002625  x4</p> <p>000093  x1</p> <p>000007  8x28 x8</p>	<p>005381  H0 x8</p> <p>004828  Kr0 x8</p> <p>000021  3,5x16 x16</p>	<p>000010  x4</p> <p>000200  x4</p> <p>000007  8x28 x2</p> <p>000020  4x30 x10</p>	<p>000071  8x40 4x45° x1</p> <p>000073  x1</p> <p>000070  3,5x13 x2</p>
<p>005279  L959 x1</p>				

2

004992  x16

005381  x8
H0

004838  x2

000070  3,5x13 x2

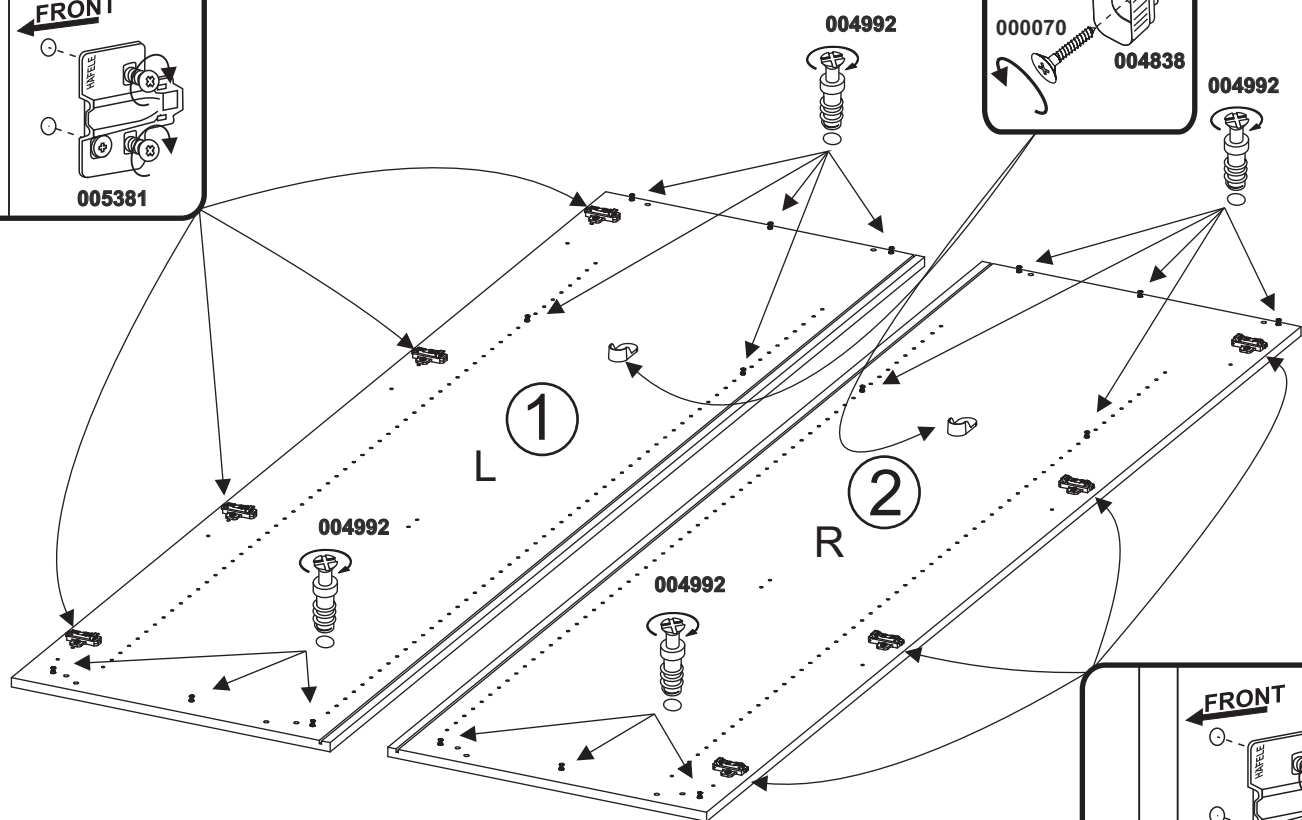
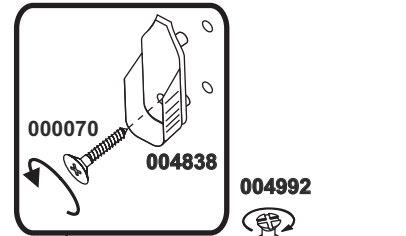
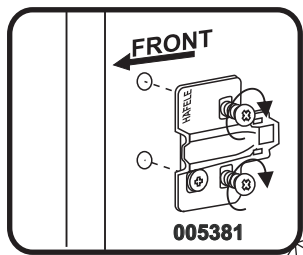

3

000007  8x28 x8

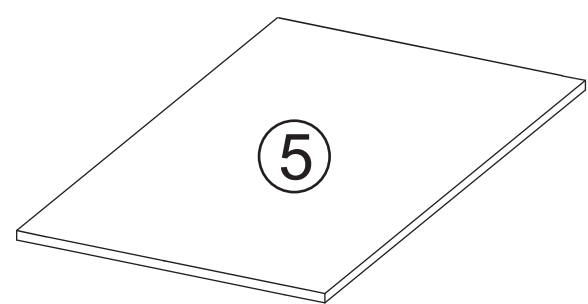
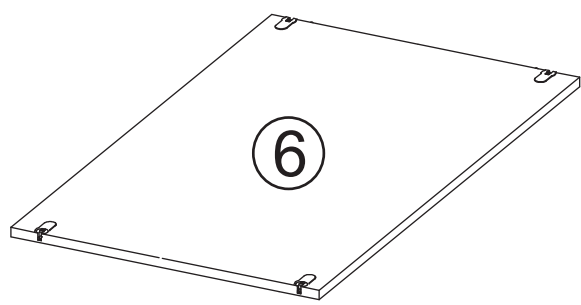
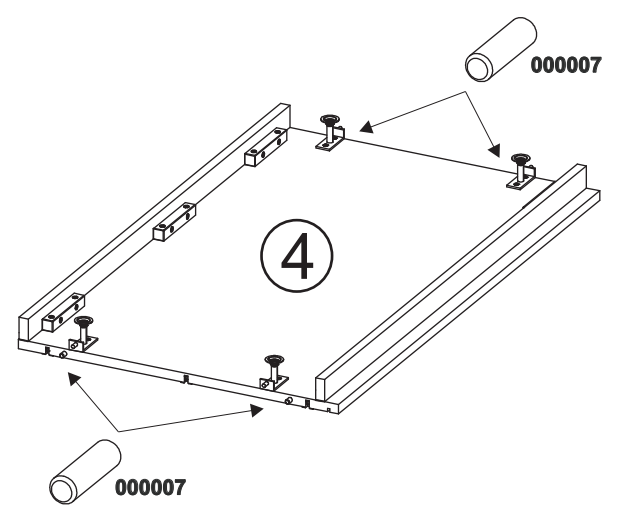
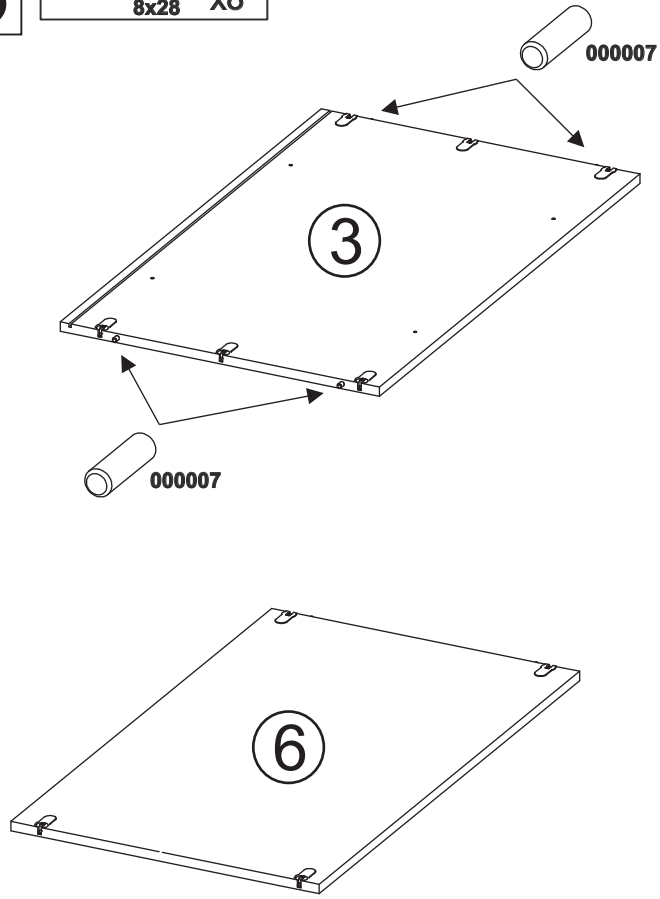

4

000010  x4

000200  x4

000007  8x28 x2

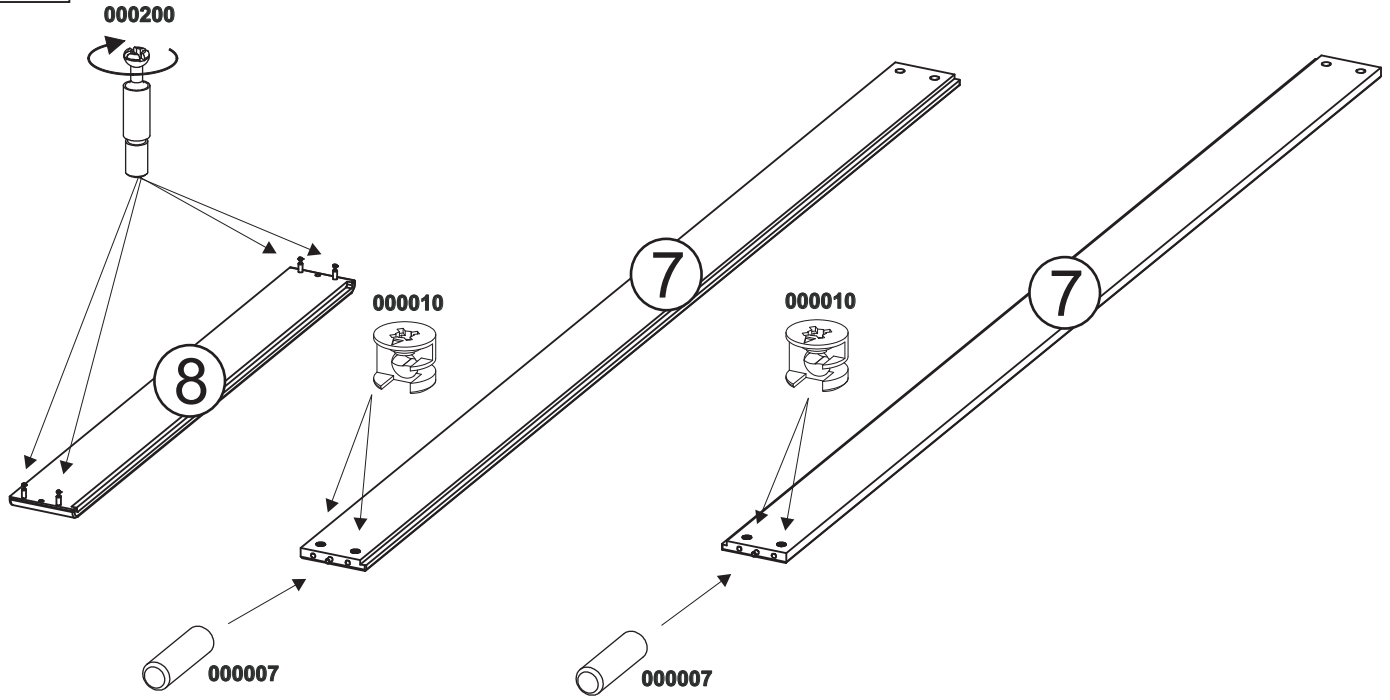

5

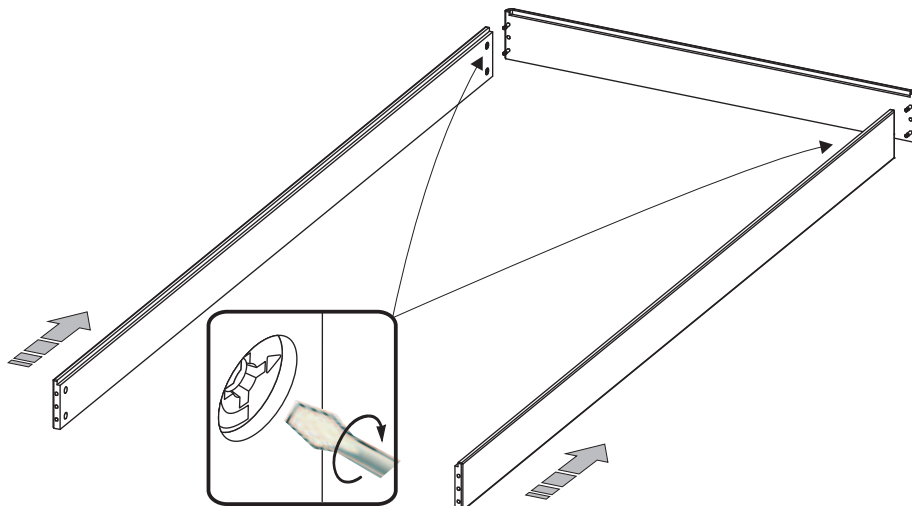

6

004828  Kr0 x8

000021  3,5x16 X16

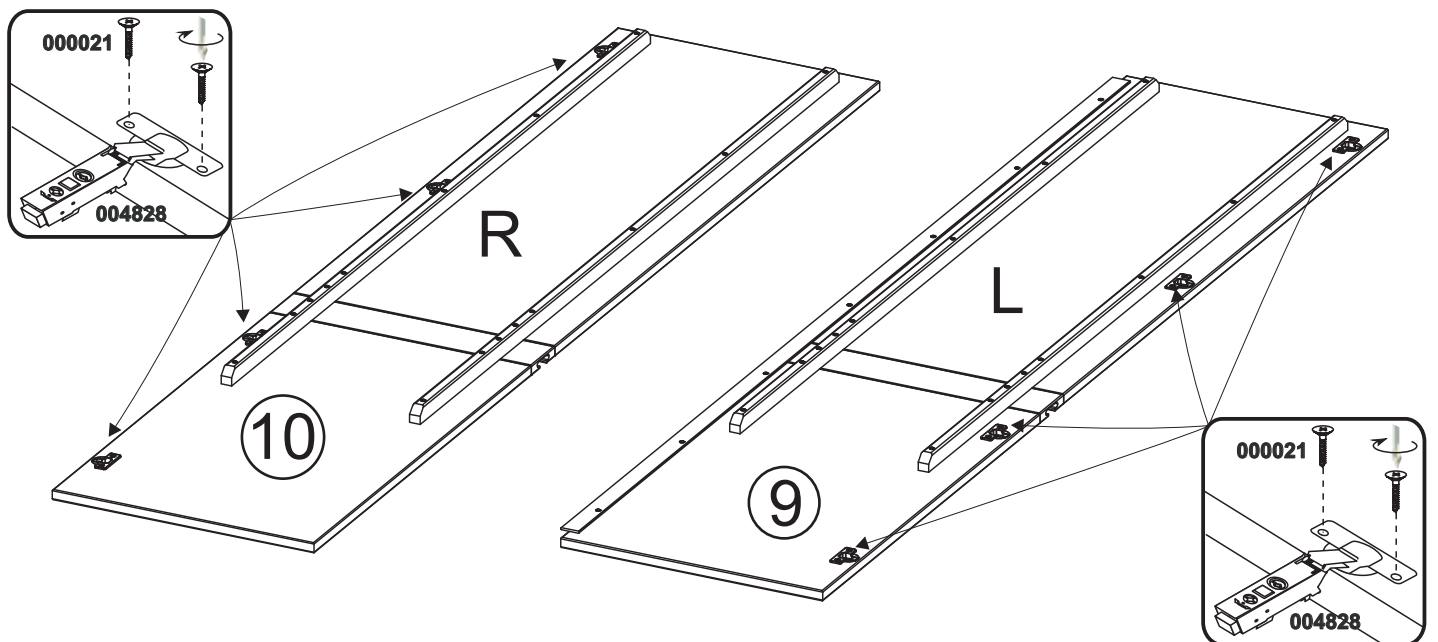

7

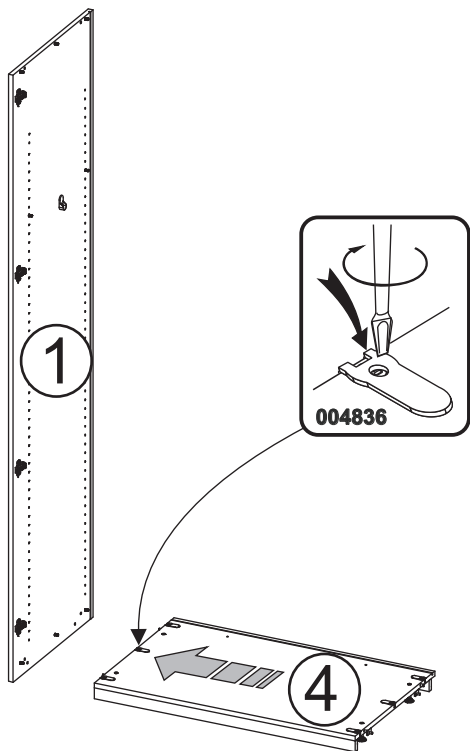

8

002629 x4

000021 x 3,5x16 X4

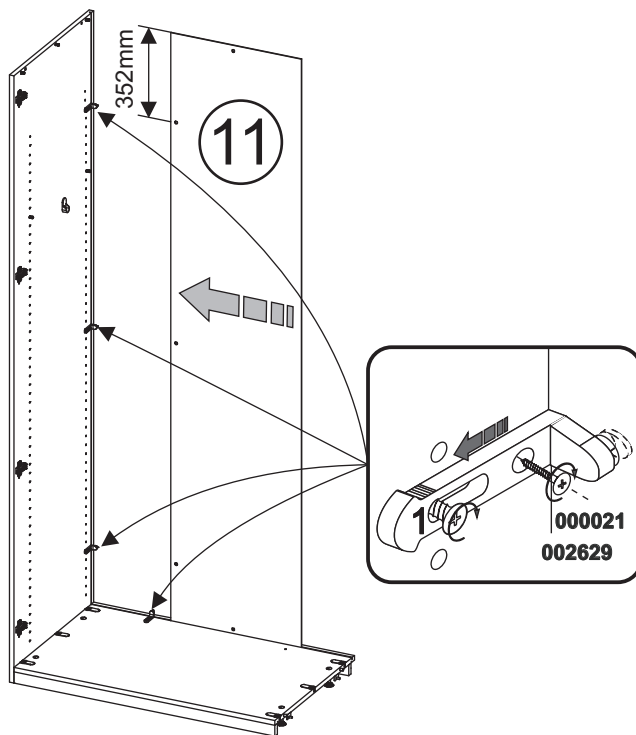

9

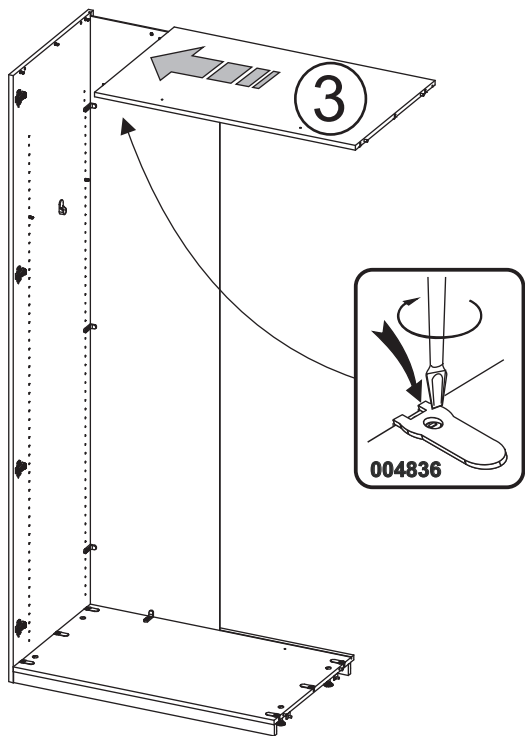

10

002629 x3

000021 x 3,5x16 X3

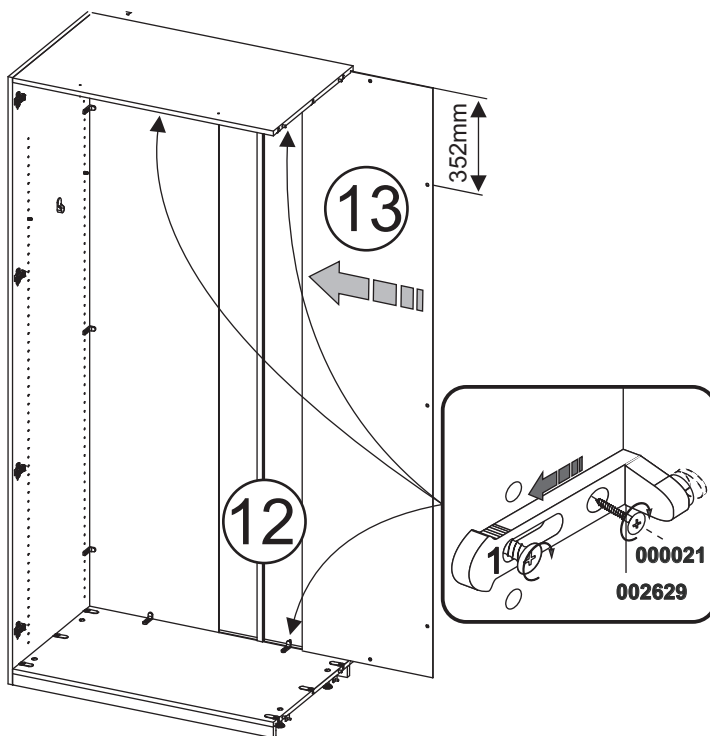

11

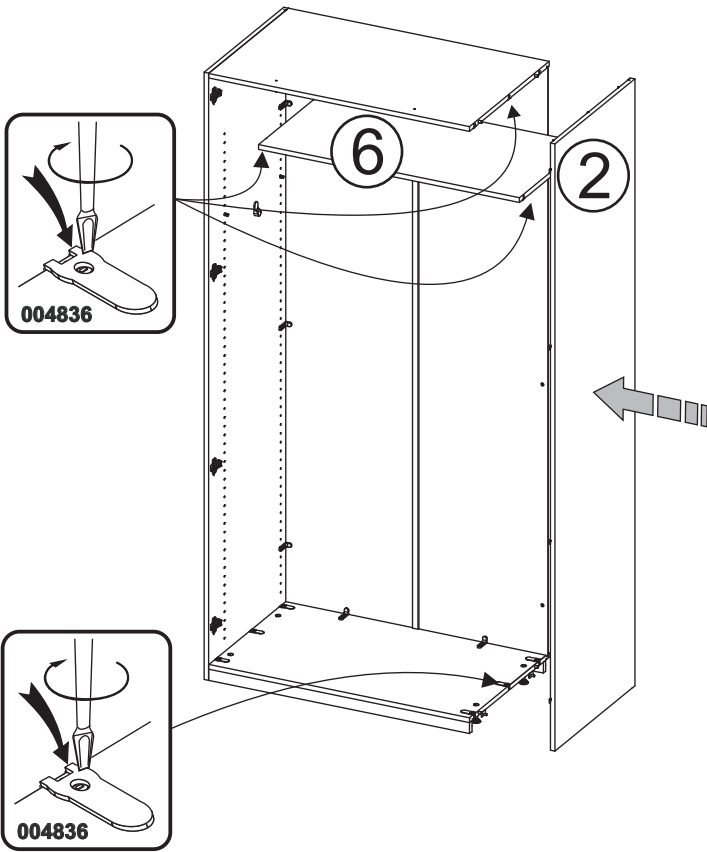

12

005279 L959 x1
002625 x4

000021 3,5x16 x3
002629 x3

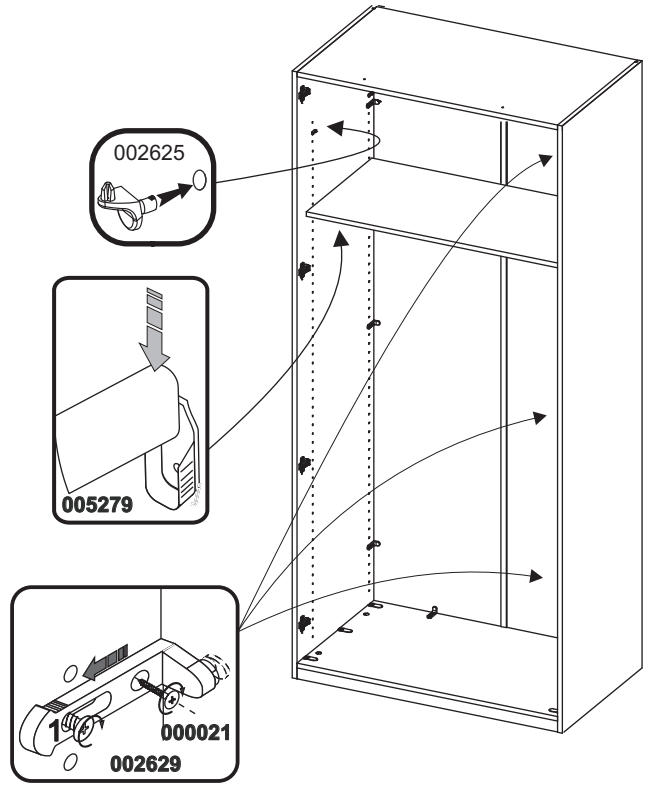

13

000073 x1

000070 3,5x13 x2

000071 8x40 4x45 x1

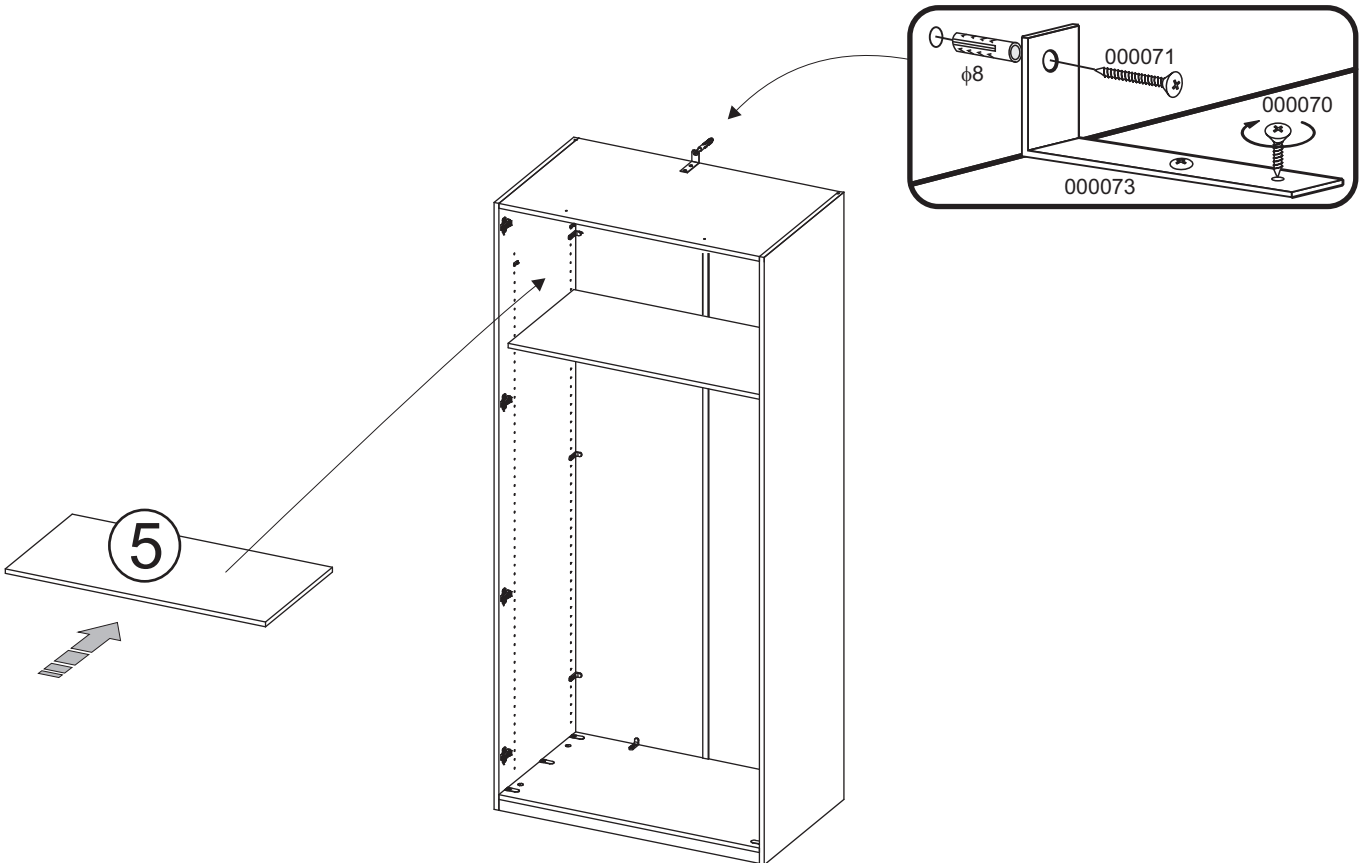

14

000020
4x30 x10

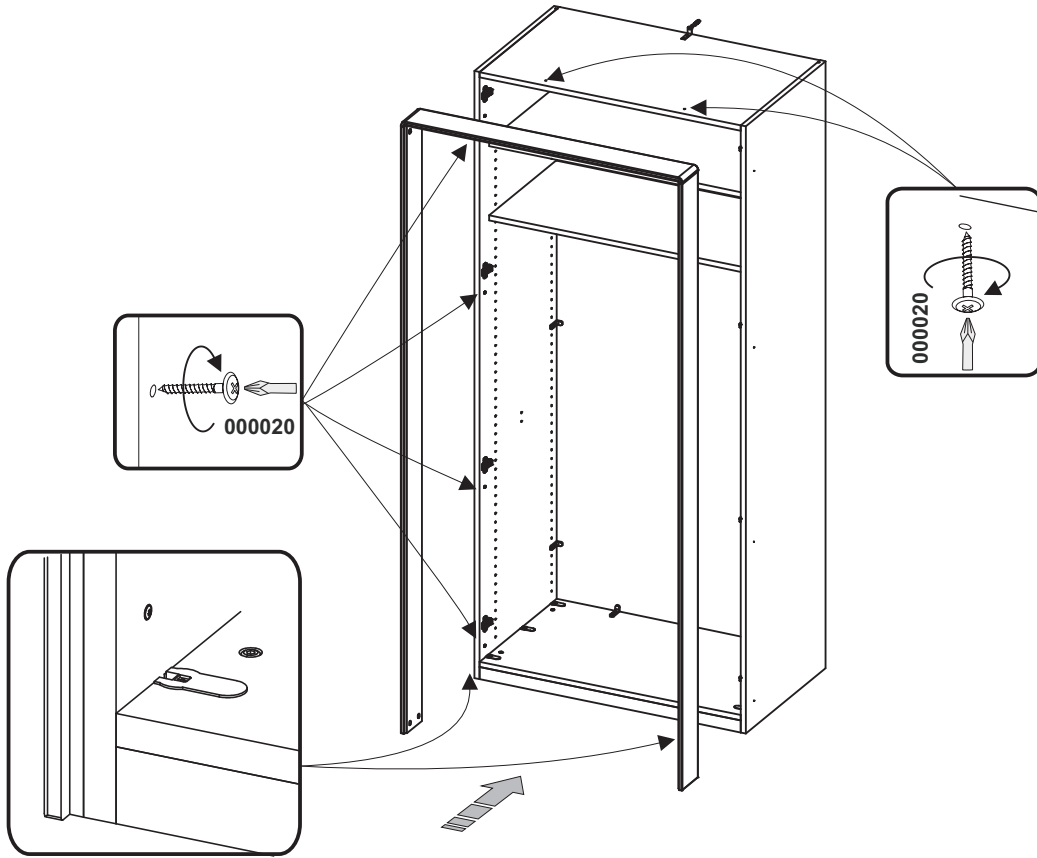

15

000093
x1

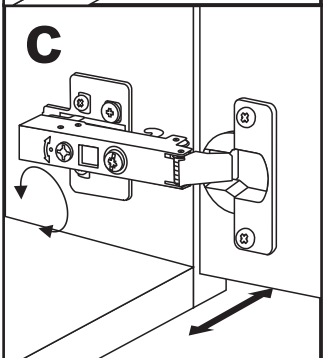
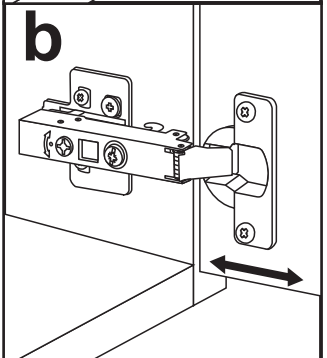
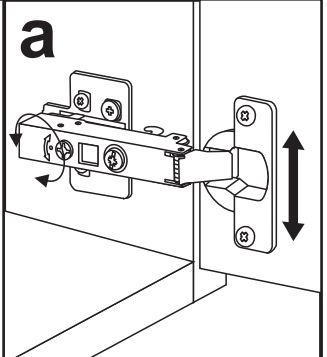
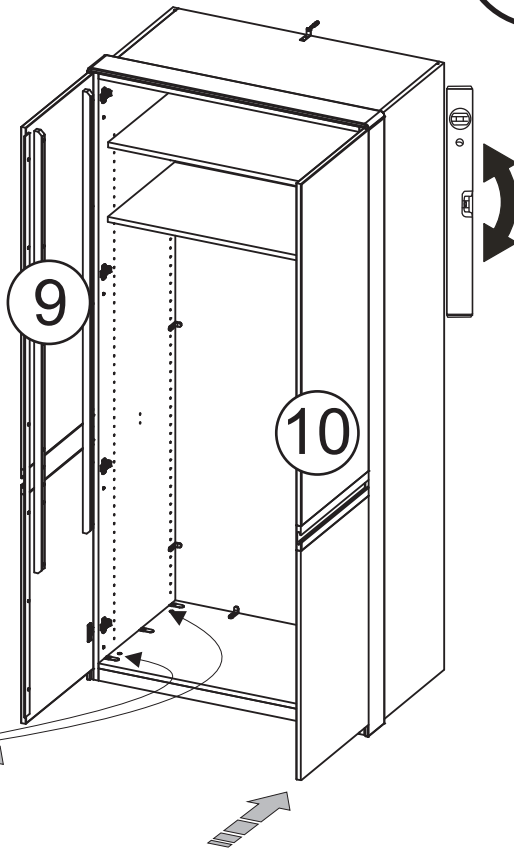
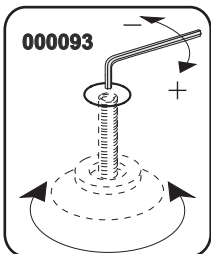
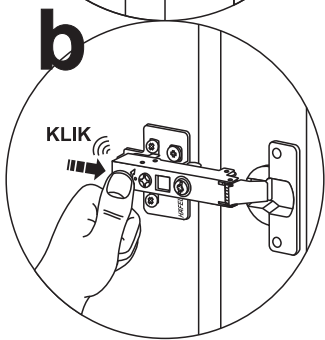
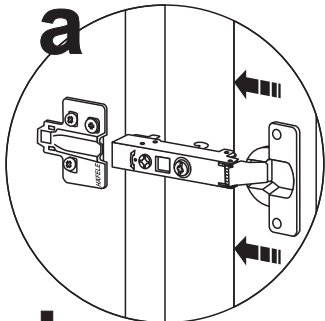

Nazwa modelu: **ATLANTA**

Numer modelu: **02**

KARTA SERWISOWA



Smolniki 14-200 Iława

Uwaga! Niniejsza karta jest podstawą przy uwzględnieniu reklamacji

Szanowny Kliencie, gdyby brakowało jakiejś części lub byłaby uszkodzona proszę to oznaczyć krzyżykiem na **karcie serwisowej** i przesłać **kartę serwisową** razem z reklamacją.

Nadawca:

.....

.....

.....

Proszę koniecznie wypełnić!
Gdzie kupione: Dom Handlowy i miejscowość

.....

.....

.....

Opis wady:

.....

.....

.....

.....

.....

Data nabycia:

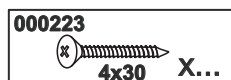
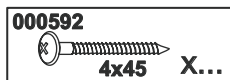
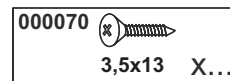
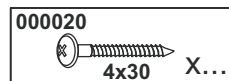
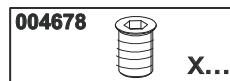
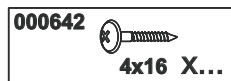
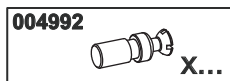
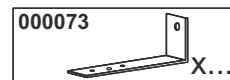
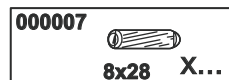
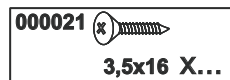
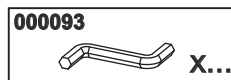
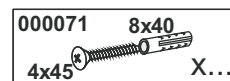
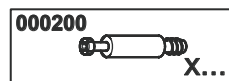
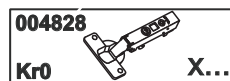
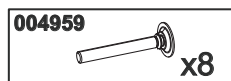
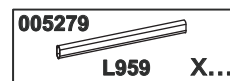
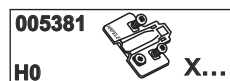
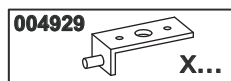
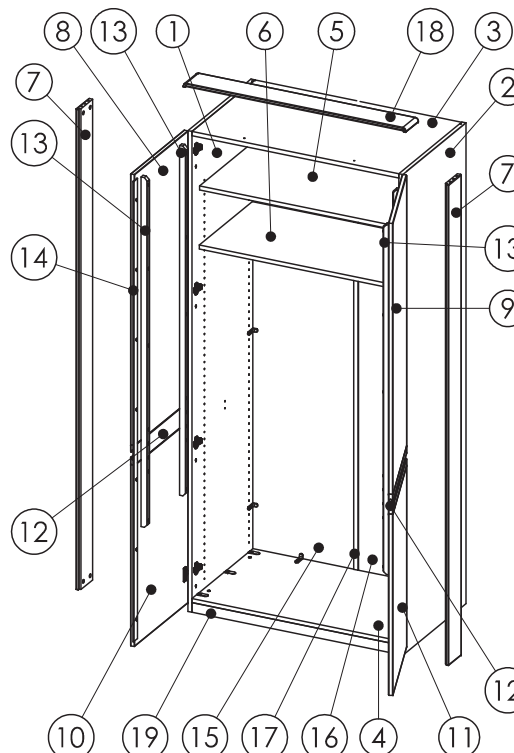

Nr serii:

Nr kontroli jakości: